

Gritmon, Marcie M.

From: Berner, Aaron
Sent: Friday, January 30, 2009 3:50 PM
To: 'Wayne Rogers'
Cc: Mittan, Jeannette; Gritmon, Marcie M.; kwesber@firstenergycorp.com; Mike Thorn (mthorn@firstenergycorp.com); esnyder@firstenergycorp.com; mjudnick@firstenergycorp.com; dcardy@firstenergycorp.com
Subject: Queue Position #U3-018 Generation Interconnection Feasibility Study
Attachments: PJMDOCS-#523656-v1-U3-018_SISA.pdf; PJMDOCS-#523510-v1-U3-018_Feasibility_Study.pdf

Wayne,

Attached is a report documenting the results of the U3-018 Generation Interconnection Feasibility Study. The results of these studies are predicated on a year 2012 transmission system, based on PJM's best assumptions at the present time for load growth and for connection of proposed new generation additions.

Please respond acknowledging receipt of this email with attachments.

Generation Interconnection Feasibility Studies are performed to determine the facilities required for interconnection and to define the cost and timing for construction of direct connection facilities and transmission network upgrades required for the reliable interconnection of a generation project to the transmission system. The direct connection facilities and network upgrade costs and associated timing described in the enclosed report are based upon estimates given to PJM by FirstEnergy. The costs are your responsibility as the Interconnection Customer. The project was evaluated for system normal conditions and single contingency outage conditions. In addition, tower line outages, which are anticipated to have a significant cost or timing impact on the interconnection of the projects, were assessed.

Pursuant to Section 204.3 of the PJM Tariff, attached is a System Impact Study Agreement for your consideration. The Agreement must be executed within thirty days (by close of business on **March 4, 2009**) to maintain the project's position in the queue. Please note that a refundable deposit of **\$50,000** is required to accompany the signed Agreement. Two copies, with original signature on each, of the executed System Impact Study Agreement should be returned with the required study deposit to:

Jeannette Mittan
PJM Interconnection, L.L.C.
955 Jefferson Avenue, Business Center
Valley Forge Corporate Center
Norristown, PA 19403-2497
Phone: (610) 666-3158
FAX: (610) 666-4779

The following information is provided for wire transfers: Bank: PNC Bank, NA, New Jersey; ABA Number: 031-207-607; Account Number: 8013589826. Please e-mail Jeannette Mittan at mittaj@pjm.com with the project name, queue number, date and amount of wire.

In order to properly model this Interconnection Request, please provide the information requested on this link, <http://www.pjm.com/planning/rtep-development/expansion-plan-process/form-impact-study-data.aspx>, and submit it electronically.

Additionally, please ensure all requirements of Section 204.3 of the PJM Tariff are met. PJM shall require the all information by be supplied by **March 4, 2009**.

Please note that failure to return the executed System Impact Study Agreement, supply data as required by Section 204.3 of the PJM Tariff, and posting the study deposit as required per Section 204.3 of the PJM Tariff by the dates contained in this email, will result in this Interconnection Request being terminated and withdrawn.

Costs for the Generation Interconnection Feasibility Study are being tabulated and you will receive an invoice for any amount owed to PJM for the analysis.

If you desire to discuss the Generation Interconnection Feasibility Study Report or the System Impact Study Agreement in more detail, please call me at (610) 666-8951 or email me at bernea@pjm.com. A meeting or teleconference can be arranged for your convenience.

Aaron Berner
PJM Interconnection
955 Jefferson Drive
Norristown, PA 19403
Office 610-666-8951
Cell 610-945-6313
Fax 610-666-4779
bernea@pjm.com

***Generation Interconnection Feasibility Study
Report***

***PJM Generation Interconnection Request
Queue Position #U3-018
Knieriem
20MW
(2.6MW capacity)***

January 2009

Preface

The intent of the Generation Interconnection Feasibility Study is to determine a plan, with ballpark cost and construction time estimates, to connect the subject generation interconnection project to the PJM network at a location specified by the Interconnection Customer. As a requirement for interconnection, the Interconnection Customer may be responsible for the cost of constructing Network Upgrades, which are facility additions, or upgrades to existing facilities, that are needed to maintain the reliability of the PJM system.

The proposed interconnection facilities must be designed in accordance with the FirstEnergy “Requirements for Transmission Connected Facilities” document. Procedures for gaining access to these standards can be found at the link below.

<http://www.pjm.com/planning/design-engineering/to-tech-standards.aspx>

In some instances an Interconnection Customer may not be responsible for 100% of the identified Network Upgrade cost because other transmission network uses, e.g. another generation interconnection or merchant transmission upgrade, may also contribute to the need for the same network reinforcement. The possibility of sharing the reinforcement costs with other projects may be identified in the Generation Interconnection Feasibility Study, but the actual allocation will be deferred until the System Impact Study is performed.

The Generation Interconnection Feasibility Study estimates do not include the feasibility, cost, or time required to obtain property rights and permits for construction of the required facilities unless noted in the report. The project Interconnection Customer is responsible for acquiring any necessary right of way and real estate, as well as applying for and obtaining any and all permits unless prior agreement by interested parties allows for other arrangements. For properties currently owned by Transmission Owners, some permitting and real estate costs may be included in the study.

Cost and Timing Estimates

The estimates in this report do not include tax gross-up.

While the information in this transmittal is reasonable for the scope of work defined, it should, however, be noted that the cost figures and time estimates are conceptual in nature at this stage, as an engineering team has not been assigned to the project. Any change to the scope of work will require that the estimates be revisited. The costs are a best estimate, but the Interconnection Customer will be charged for actual costs. Any under-runs or over-runs will be reconciled at the conclusion of the project.

General

The Queue Position #U3-018 project was studied as a 20MW and 2.6 MWC (capacity) injection into the PENELEC system at the Meyersdale North 23 kV bus. U3-018 was evaluated for compliance with reliability criteria for summer peak conditions in 2012.

Metering

The Interconnection Customer will be required to install and maintain metering and telemetry equipment to provide revenue metering and real-time telemetry data to PJM and the Transmission Owner. The PJM requirements for this equipment are listed in Appendix 2, section 8 of Attachment O to the PJM Tariff, as well as PJM Manuals 01 and 14D. The PJM and Transmission Owner requirements for Metering Equipment will be discussed in more detail in subsequent studies.

PENELEC Revenue Metering Requirements for Generation Interconnection Customer

Interconnection Customer shall install, own, operate, test and maintain the necessary revenue quality Metering Equipment. This includes current transformers, voltage transformers, mounting structures, wiring, meters, communication circuits, and associated devices. The Metering Equipment must meet the specifications listed in the FirstEnergy connection documents. The FirstEnergy “Requirements for Transmission Connected Facilities” can be retrieved from:

<http://www.pjm.com/planning/design-engineering/to-tech-standards.aspx>

The Metering Equipment shall be located at the generation facility on the high voltage side of the generator step-up transformers or facility main step-up transformer and/or station service power transformers. Power flows to and from the facility shall be compensated to the Point of Interconnection.

Penelec will provide revenue quality Metering Equipment for a station service power supply at a generation facility if the supply is from the local Penelec distribution system.

The revenue quality Metering Equipment shall be capable of collecting and storing bidirectional billing data. The billing data shall be stored in intervals specified by Penelec, typically fifteen minutes or thirty minutes. The Interconnection Customer must provide Penelec with remote access to the billing data in the Metering Equipment via a dedicated voice-grade analog telephone circuit. The Interconnection Customer shall provide Penelec with contact information for the person or persons responsible for meter programming and Metering Equipment maintenance.

The Interconnection Customer shall consult with Penelec regarding the revenue quality metering system design and provide the following information:

- Facility one line and revenue metering installation drawings (schematics, wiring diagrams, etc.)
- Estimated power flows to and from the facility at all revenue metering points
- Current transformer and voltage transformer specifications, including manufacturer, type, nameplate drawings, and certified accuracy test reports
- Revenue meter specifications including manufacturer, type, model number, and accuracy

- Revenue meter program information including but not limited to billing data recorder channel assignments, recorder pulse weights (Ke), and read-only password for access to interval data by the FirstEnergy billing data collection system (MV-90)
- Revenue meter telephone number
- Revenue meter loss compensation data (if applicable)

The Interconnection Customer shall provide Penelec with prior notification of any modifications at the facility that will affect the revenue meter measurements, including substation reconfigurations and meter program changes.

The revenue metering system at each location shall be tested for accuracy by the Interconnection Customer once every two years. The Interconnection Customer shall give reasonable notice to Penelec of the time when the testing is scheduled so that Penelec may have representatives present. Penelec shall have the right to audit the revenue Metering Equipment and/or related documents. The Interconnection Customer shall be given a reasonable period of time to comply with any requests associated with an audit.

Design Requirements

The generation owner is responsible for specifying appropriate equipment and facilities such that the parallel generation is compatible with the Penelec Transmission System. The generation owner is also responsible for meeting any applicable federal, state, and local codes. It is also the Interconnection Customer's responsibility to obtain any needed right-of-way between the plant site and Penelec's facilities.

Penelec will complete detailed relay coordination studies to identify off-site relay setting changes required due to this generation interconnection during the Facilities Study on construction phase of this project. This may result in additional individual relay replacements being required. These relay replacements will be done at the cost of the Interconnection Customer.

Reactive Power

Requirements to be provided during the System Impact Study or Facilities Study phase of the project studies.

Cost and Timing Estimates

While the information in this transmittal is reasonable for the scope of work defined, it should, however, be noted that the cost figures and time estimates are conceptual in nature at this stage, as an engineering team has not been assigned to the project. Any change to the scope of work will require that the estimates be revisited. The costs are a best estimate, but the Interconnection Customer will be charged for actual costs. Any under-runs or over-runs will be reconciled at the conclusion of the project.

Cost Estimates provided in this report were derived from estimates received in association with other similar projects.

Direct Connection Facilities

The Interconnection Customer is responsible for constructing all of the facilities on its side of the Point of Interconnection.

The proposed Interconnection Facilities must be designed in accordance with the FirstEnergy “Requirements for Transmission Connected Facilities” document. Procedures for gaining access to these standards can be found at the link below.

<http://www.pjm.com/planning/design-engineering/to-tech-standards.aspx>

Below are conceptual estimates for the engineering/construction associated with direct connection requirements based upon similar projects that have been designed and/or constructed. The cost below is based on U3-018 being the only project to connect at this substation.

Item	Description	Conceptual Cost Estimate
1	New 23 kV breaker termination point at Meyersdale North 23kV substation.	\$300,000
2	23 kV transmission line extending from Allegheny substation structure to the generation plant substation.	Developer cost. Line built, owned and maintained by the developer.
3	23kV transmission line extending from the new interconnection substation structure to the generation plant substation.	N/A Interconnection Customer cost. Line built, owned and maintained by the Interconnection Customer.
	Additional communications and control evaluations which occur during the System Impact Study may develop relay and control work at remote 115kV substations	

Conceptual Estimate: \$300,000
 Estimated Lead Time: 1.5 years from signed CSA

Notes:

Detailed Engineering & Construction Estimates to be determined during subsequent phase(s) of this projects development.

The above estimates do not include 1) tax gross-up, 2) property costs and site development up to rough grade which is to be provided by the Interconnection Customer, 3) interconnection metering

and generation SCADA to be provided by the Interconnection Customer, and 4) engineering and field activities for design review and commissioning of the Interconnection Customer's facilities

Potential network impacts were as follows:

Network Impacts

Generator Deliverability

(Single or N-1 contingencies for the Capacity Resource portion only of the interconnection)

No problems were identified

Multiple Facility Contingency

(Double Circuit Tower Line for the full energy output. Stuck breaker and bus fault contingencies will be performed for the System Impact Study)

No problems were identified

Contribution to Previously Identified Overloads

(This project contributes to the following contingency overloads, i.e. "Network Impacts", identified for earlier generation or transmission interconnection projects in the PJM Queue)

1. The **Hillclay – Hilltop** 115 kV line loads (bus# 461- 462) from **244.62% to 248.74%** of its emergency rating (179 MVA) for tower line outage contingency (2PN_WITH_S11A). This project contributes approximately **7.37 MW** to cause this thermal violation. To mitigate this overload would require replacement/upgrade of a disconnect switch (estimated to cost approximately \$80,000), a line/wave trap (estimated to cost approximately \$115,000), substation conductor (estimated to cost approximately \$375,000), CT circuit (estimated to cost \$125,000), and circuit breaker (estimated to cost approximately \$225,000) at Hilltop Substation and the construction of 5 miles of new 115 kV line (estimated to cost \$2,500,000).
2. The **Hooversv – Scalp L** 115 kV line loads (bus# 453- 444) from **235.55% to 240.2%** of its emergency rating (179 MVA) for tower line outage contingency (2PN_WITH_S11A). This project contributes approximately **8.33 MW** to cause this thermal violation. To mitigate this overload would require the construction of 6.92 miles of NEW transmission line (estimated to cost approximately \$3,460,000) and the replacement/upgrade of a disconnect switch (estimated to cost approximately \$80,000), a CT circuit (estimated to cost approximately \$125,000), a line/wave trap (estimated to cost approximately \$115,000), a circuit breaker (estimated to cost approximately \$225,000), and substation conductor (estimated to cost approximately \$125,000) at Hooversville Substation and the replacement/upgrade of a disconnect switch (estimated to cost approximately \$80,000), and substation conductor (estimated to cost approximately \$125,000) at Scalp Level Substation.
3. The **Garrett – 01Garrett** 115 kV line loads (bus# 472- 20470) from **232.09% to 238.68%** of its emergency rating (125 MVA) for tower line outage contingency (2PN_WITH_S11A).

This project contributes approximately **8.24 MW** to cause this thermal violation. To mitigate this overload would require the replacement of substation conductor (estimated to cost approximately \$125,000), the replacement of a disconnect switch (estimated to cost approximately \$80,000), and the replacement of two CT circuits (estimated to cost approximately \$250,000) at Garrett substation. It also requires the reconductor of 1.9 miles of 115 kV transmission line between Garrett and Garrett Tap (estimated cost approximately \$522,500).

4. The **Scalp L – Rachel H** 115 kV line loads (bus# 444- 459) from **228.66% to 233.31%** of its emergency rating (179 MVA) for tower line outage contingency (2PN_WITH_S11A). This project contributes approximately **8.33 MW** to cause this thermal violation. To mitigate this overload would require the construction of 2.7 miles of NEW transmission line (estimated to cost approximately \$1,350,000) and the replacement/upgrade of a disconnect switch (estimated to cost approximately \$80,000), a CT circuit (estimated to cost approximately \$125,000), a line/wave trap (estimated to cost approximately \$115,000), a circuit breaker (estimated to cost approximately \$225,000), and substation conductor (estimated to cost approximately \$125,000) at Rachel Hill Substation and the replacement/upgrade of a disconnect switch (estimated to cost approximately \$80,000), and substation conductor (estimated to cost approximately \$125,000) at Scalp Level Substation.
5. The **Rachel H – Hillclay** 115 kV line loads (bus# 459- 461) from **203.21% to 207.74%** of its emergency rating (184 MVA) for tower line outage contingency (2PN_WITH_S11A). This project contributes approximately **8.33 MW** to cause this thermal violation. To mitigate this overload would require the construction of 3.06 miles of NEW transmission line (estimated to cost approximately \$1,530,000) and the replacement/upgrade of a disconnect switch (estimated to cost approximately \$80,000) at Hillclay Junction and the replacement/upgrade of a line/wave trap (estimated to cost approximately \$115,000), substation conductor (estimated to cost approximately \$125,000), and disconnect switch (estimated to cost approximately \$80,000) at Rachel Hill Substation.
6. The **Rockwood - Penn-Mar** 115 kV line loads (bus# 456- 457) from **201.67% to 207.43%** of its emergency rating (143 MVA) for tower line outage contingency (2PN_WITH_S11A). This project contributes approximately **8.24 MW** to cause this thermal violation. To mitigate this overload would require the replacement / upgrade of a disconnect switch (estimated to cost approximately \$80,000) and substation conductor (estimated to cost approximately \$250,000) at Rockwood substation. It also requires the replacement/upgrade of a CT circuit (estimated cost approximately \$125,000), circuit breaker (estimated cost approximately \$225,000), line/wave trap (estimated to cost approximately \$115,000) and substation conductor (estimated to cost approximately \$375,000) at Penn Marr Substation and the construction of 15 miles of new 115 kV line (estimated cost approximately \$7,500,000).
7. The **Penn-Mar - Garrett** 115 kV line loads (bus# 457- 472) from **172.9% to 177.84%** of its emergency rating (167 MVA) for tower line outage contingency (2PN_WITH_S11A). This project contributes approximately **8.24 MW** to cause this thermal violation. To mitigate this overload requires the replacement/upgrade of a line trap and substation conductor at Penn Mar 115 kV substation (estimated cost approximately \$240,000). It also

require the reconductor of approximately 14.95 miles of 115 kV transmission line (estimated cost approximately \$4,111,250).

8. The **Hilltop - Rosedale** 115 kV line loads (bus# 462- 463) from **152.46% to 155.46%** of its emergency rating (179 MVA) for tower line outage contingency (2PN_WITH_S11A). This project contributes approximately **5.36 MW** to cause this thermal violation. To mitigate this overload would require the replacement/upgrade of a line trap, two (2) disconnect switches, a CT circuit, circuit breaker, and substation conductor at Hilltop 115 kV substation (estimated cost approximately \$875,000). It also requires the reconductor of approximately 1.54 miles of 115 kV transmission line (estimated cost approximately \$423,500).

Short Circuit

PJM studied the 230kV and above voltage systems and found no new breakers to be overdutied, and no addition to the fault current associated with any previously identified overdutied breakers. Additional short circuit study will be conducted during the System Impact Study phase of this project.

Steady-State Voltage Requirements

(Results of the steady-state voltage studies should be inserted here)

To be determined during the System Impact Study phase of the study of this project.

Stability and Reactive Power Requirement

(Results of the dynamic studies should be inserted here)

To be determined during the System Impact Study or Facilities Study phase of the study of this project.

Delivery of Energy Portion of Interconnection Request

PJM also studied the delivery of the energy portion of this interconnection request. Any problems identified below are likely to result in operational restrictions to the project under study. The Interconnection Customer can proceed with network upgrades to eliminate the operational restriction at their discretion by submitting a Merchant Transmission Interconnection request Note: Only the most severely overloaded conditions are listed below. There is no guarantee of full delivery of energy for this project by fixing only the conditions listed in this section. With a Transmission Interconnection Request, a subsequent analysis will be performed which shall study all overloaded conditions associated with the overloaded element(s) identified.

As a result of the aggregate energy resources in the area, the following violations were identified:

1. The Hooversv-Tower 51 115 kV line loads (bus# 453- 452) from 260.38% to 265.39% (DC power flow) of its emergency rating (146 MVA) for the single line contingency outage (PN37_R56OP1A). This project contributes approximately 7.31 MW to the thermal congestion.
2. The S-011C-Seward 115 kV line loads (bus# 90216- 451) from 258.07% to 262.61% (DC power flow) of its emergency rating (159 MVA) for the single line contingency outage (PN37_R56OP1A). This project contributes approximately 7.21 MW to the thermal congestion.
3. The Tower-S-011C 115 kV line loads (bus# 452- 90216) from 221.57% to 226.1% (DC power flow) of its emergency rating (159 MVA) for the single line contingency outage (PN37_R56OP1A). This project contributes approximately 7.21 MW to the thermal congestion.
4. The Q34-Somerset 115 kV line loads (bus# 95280- 454) from 141.58% to 154.16% (DC power flow) of its emergency rating (159 MVA) for the single line contingency outage (APS-SB-662). This project contributes approximately 20.00 MW to the thermal congestion.
5. The 01Garret 115-138 kV transformer loads (bus# 20470- 20469) from 250.12% to 272.34% (DC power flow) of its emergency rating (90 MVA) for the single line contingency outage (SOMERST_Q34). This project contributes approximately 20.00 MW to the thermal congestion.
6. The 01Garret 115-138 kV transformer loads (bus# 20470- 20469) from 197.15% to 207.22% (DC power flow) of its normal rating (90 MVA) for the non-contingency

condition. This project contributes approximately 6.34 MW to the thermal congestion.

7. The 01Blacko 138-500 kV transformer loads (bus# 20446- 20103) from 105.21% to 106.51% (DC power flow) of its emergency rating (437 MVA) for the single line contingency outage (SOMERST_Q34). This project contributes approximately 5.65 MW to the thermal congestion.
8. The Somerset – Hooversville 115 kV circuit loads from 107% to 111% (DC power flow) of its emergency rating (179 MVA) for the single contingency outage (Claysburg – Curryville – Saxton 115 kV). This project contributes approximately 7 MW to the thermal congestion.

Option 2:

Secondary Point of Interconnection – Results provided in terms of a sensitivity analysis. No reinforcements and associated costs are provided for this option.

Network Impacts

The queue project U3-018 was studied as a 20MW and 2.6 MWC (capacity) injection into the PENELEC system at the Meyersdale North 115 kV line. U3-018 was evaluated for compliance with reliability criteria for summer peak conditions in 2012. Potential network impacts were as follows:

Generator Deliverability

(Single or N-1 contingencies for the Capacity portion only of the interconnection)

No problems were identified

Multiple Facility Contingency

(Double Circuit Tower Line contingencies only for the full energy output. Stuck breaker and bus fault contingencies will be performed for the Impact Study)

No problems were identified

Contribution to Previously Identified Overloads

(This project contributes to the following contingency overloads, i.e. “Network Impacts”, identified for earlier generation or transmission interconnection projects in the PJM Queue)

1. The **Hillclay – Hilltop** 115 kV line loads (bus# 461- 462) from **244.62% to 248.74%** of its emergency rating (179 MVA) for tower line outage contingency (2PN_WITH_S11A). This project contributes approximately **7.37 MW** to cause this thermal violation.
2. The **Hooversv – Scalp L** 115 kV line loads (bus# 453- 444) from **235.55% to 240.2%** of its emergency rating (179 MVA) for tower line outage contingency (2PN_WITH_S11A). This project contributes approximately **8.33 MW** to cause this thermal violation.

3. The **Garrett – 01Garrett** 115 kV line loads (bus# 472- 20470) from **232.09% to 238.68%** of its emergency rating (125 MVA) for tower line outage contingency (2PN_WITH_S11A). This project contributes approximately **8.24 MW** to cause this thermal violation.
4. The **Scalp L – Rachel H** 115 kV line loads (bus# 444- 459) from **228.66% to 233.31%** of its emergency rating (179 MVA) for tower line outage contingency (2PN_WITH_S11A). This project contributes approximately **8.33 MW** to cause this thermal violation.
5. The **Rachel H – Hillclay** 115 kV line loads (bus# 459- 461) from **203.21% to 207.74%** of its emergency rating (184 MVA) for tower line outage contingency (2PN_WITH_S11A). This project contributes approximately **8.33 MW** to cause this thermal violation.
6. The **Rockwood - Penn-Mar** 115 kV line loads (bus# 456- 457) from **201.67% to 207.43%** of its emergency rating (143 MVA) for tower line outage contingency (2PN_WITH_S11A). This project contributes approximately **8.24 MW** to cause this thermal violation.
7. The **Penn-Mar - Garrett** 115 kV line loads (bus# 457- 472) from **172.9% to 177.84%** of its emergency rating (167 MVA) for tower line outage contingency (2PN_WITH_S11A). This project contributes approximately **8.24 MW** to cause this thermal violation.
8. The **Hilltop - Rosedale** 115 kV line loads (bus# 462- 463) from **152.46% to 155.46%** of its emergency rating (179 MVA) for tower line outage contingency (2PN_WITH_S11A). This project contributes approximately **5.36 MW** to cause this thermal violation.

Delivery of Energy Portion of Interconnection Request

PJM also studied the delivery of the energy portion of this interconnection request. Any problems identified below are likely to result in operational restrictions to the project under study. The Interconnection Customer can proceed with network upgrades to eliminate the operational restriction at their discretion by submitting a Merchant Transmission Interconnection request Note: Only the most severely overloaded conditions are listed below. There is no guarantee of full delivery of energy for this project by fixing only the conditions listed in this section. With a Transmission Interconnection Request, a subsequent analysis will be performed which shall study all overloaded conditions associated with the overloaded element(s) identified.

As a result of the aggregate energy resources in the area, the following violations were identified:

1. The Hooversv-Tower 51 115 kV line loads (bus# 453- 452) from 260.38% to 265.39% (DC power flow) of its emergency rating (146 MVA) for the single line contingency outage (PN37_R56OP1A). This project contributes approximately 7.31 MW to the thermal congestion.
2. The S-011C-Seward 115 kV line loads (bus# 90216- 451) from 258.07% to 262.61% (DC power flow) of its emergency rating (159 MVA) for the single line contingency outage (PN37_R56OP1A). This project contributes approximately 7.21 MW to the thermal congestion.

3. The Tower-S-011C 115 kV line loads (bus# 452- 90216) from 221.57% to 226.1% (DC power flow) of its emergency rating (159 MVA) for the single line contingency outage (PN37_R56OP1A). This project contributes approximately 7.21 MW to the thermal congestion.
4. The Q34-Somerset 115 kV line loads (bus# 95280- 454) from 141.58% to 154.16% (DC power flow) of its emergency rating (159 MVA) for the single line contingency outage (APS-SB-662). This project contributes approximately 20.00 MW to the thermal congestion.
5. The 01Garret 115-138 kV transformer loads (bus# 20470- 20469) from 250.12% to 272.34% (DC power flow) of its emergency rating (90 MVA) for the single line contingency outage (SOMERST_Q34). This project contributes approximately 20.00 MW to the thermal congestion.
6. The 01Garret 115-138 kV transformer loads (bus# 20470- 20469) from 197.15% to 207.22% (DC power flow) of its normal rating (90 MVA) for the non-contingency condition. This project contributes approximately 6.34 MW to the thermal congestion.
7. The 01Blacko 138-500 kV transformer loads (bus# 20446- 20103) from 105.21% to 106.51% (DC power flow) of its emergency rating (437 MVA) for the single line contingency outage (SOMERST_Q34). This project contributes approximately 5.65 MW to the thermal congestion.

The Somerset – Hooversville 115 kV circuit loads from 107% to 111% (DC power flow) of its emergency rating (179 MVA) for the single contingency outage (Claysburg – Curryville – Saxton 115 kV). This project contributes approximately 7 MW to the thermal congestion.



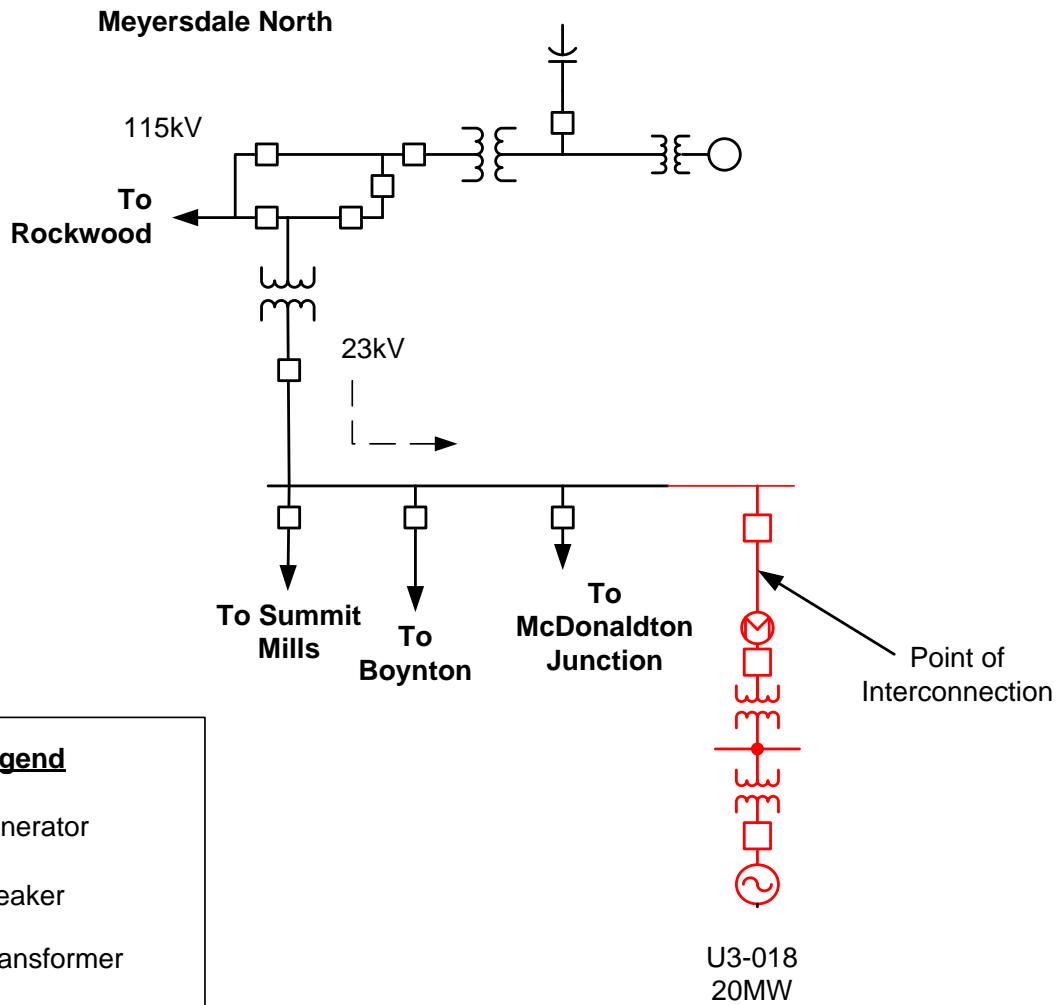

Short Circuit

To be determined.

Figure 1



Legend

-  Generator
-  Breaker
-  Transformer
-  Disconnect Switch
-  Revenue Meter

All facilities depicted in black are existing facilities. All facilities depicted in red are facilities to be added as a result of this Interconnection Request.